

## AN IC OPERATIONAL TRANSCONDUCTANCE AMPLIFIER (OTA) WITH POWER CAPABILITY

Authors: L. Kaplan and H. Wittlinger

In 1969, the first triple operational transconductance amplifier or OTA was introduced. The wide acceptance of this new circuit concept prompted the development of the single, highly linear operational transconductance amplifier, the CA3080. Because of its extremely linear transconductance characteristics with respect to amplifier bias current, the CA3080 gained wide acceptance as a gain control block. The CA3094 improved on the performance of the CA3080 through the addition of a pair of transistors; these transistors extended the current carrying capability to 300mA, peak. This new device, the CA3094, is useful in an extremely broad range of circuits in consumer and industrial applications; this paper describes only a few of the many consumer applications.

### What Is an OTA?

The OTA, operational transconductance amplifier, concept is as basic as the transistor; once understood, it will broaden the designer's horizons to new boundaries and make realizable designs that were previously unobtainable. Figure 1 shows an equivalent diagram of the OTA. The differential input circuit is the same as that found on many modern operational amplifiers. The remainder of the OTA is composed of current mirrors as shown in Figure 2. The geometry of these mirrors is such that the current gain is unity. Thus, by highly degenerating the current mirrors, the output current is precisely defined by the differential input amplifier. Figure 3 shows the output current transfer characteristic of the amplifier. The shape of this characteristic remains constant and is independent of supply voltage. Only the maximum current is modified by the bias current.

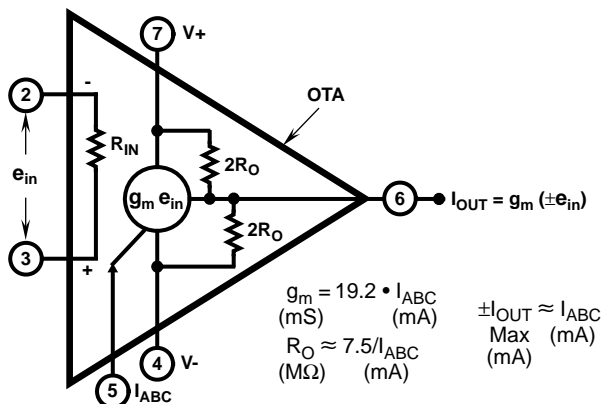


FIGURE 1. EQUIVALENT DIAGRAM OF THE OTA

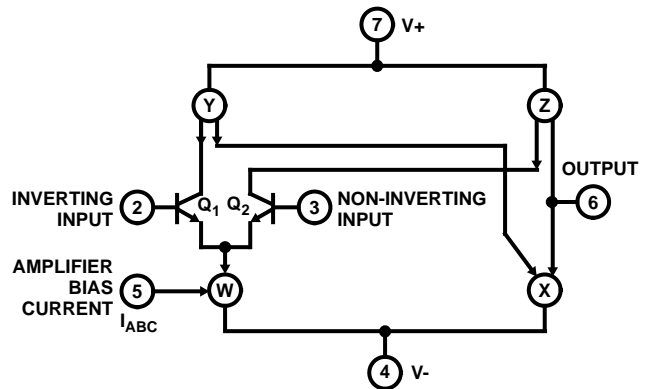


FIGURE 2. CURRENT MIRRORS W, X, Y AND Z USED IN THE OTA

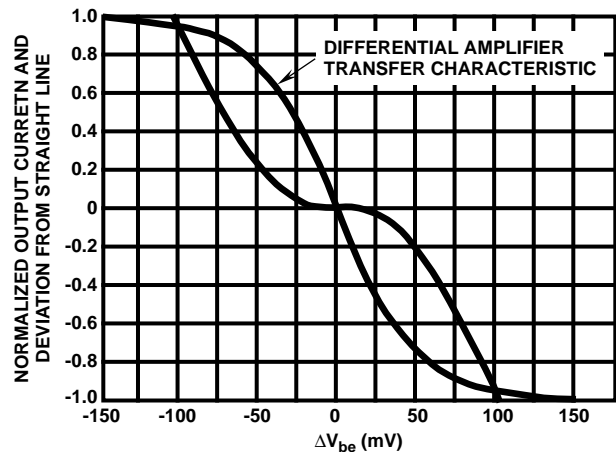


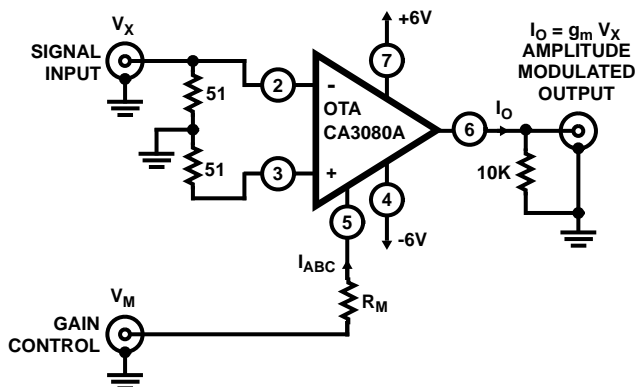
FIGURE 3. THE OUTPUT CURRENT TRANSFER CHARACTERISTIC OF THE OTA IS THE SAME AS THAT OF AN IDEALIZED DIFFERENTIAL AMPLIFIER

The major controlling factor in the OTA is the input amplifier bias current  $I_{ABC}$ ; as explained in Figure 1, the total output current and  $g_m$  are controlled by this current. In addition, the input bias current, input resistance, total supply current, and output resistance are all proportional to this amplifier bias current. These factors provide the key to the performance of this most flexible device, an idealized differential amplifier, i.e., a circuit in which differential input to single ended output conversion can be realized. With this knowledge of the basics of the OTA, it is possible to explore some of the applications of the device.

**DC Gain Control**

The methods of providing DC gain control functions are numerous. Each has its advantage simplicity, low cost, high level control, low distortion. Many manufacturers who have nothing better to offer propose the use of a four quadrant multiplier. This is analogous to using an elephant to carry a twig. It may be elegant but it takes a lot to keep it going! When operated in the gain control mode, one input of the standard transconductance multiplier is offset so that only one half of the differential input is used; thus, one half of the multiplier is being thrown away.

The OTA, while providing excellent linear amplifier characteristics, does provide a simple means of gain control. For this application the OTA may be considered the realization of the ideal differential amplifier in which the full differential amplifier  $g_m$  is converted to a single ended output. Because the differential amplifier is ideal, its  $g_m$  is directly proportional to the operating current of the differential amplifier; in the OTA the maximum output current is equal to the amplifier bias current  $I_{ABC}$ . Thus, by varying the amplifier bias current, the amplifier gain may be varied:  $A = g_m R_L$  where  $R_L$  is the output load resistance. Figure 4 shows the basic configuration of the OTA DC gain control circuit.

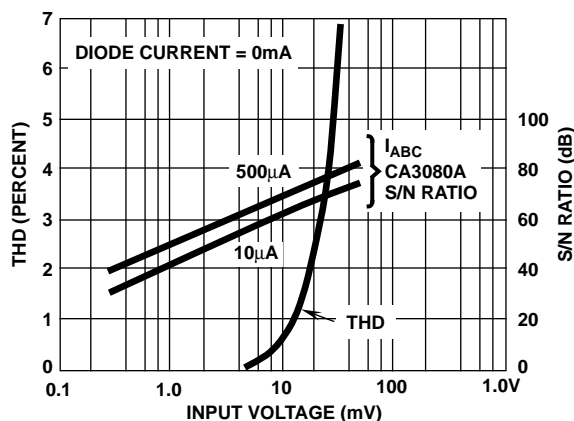


**FIGURE 4. BASIC CONFIGURATION OF THE OTA DC GAIN CONTROL CIRCUIT**

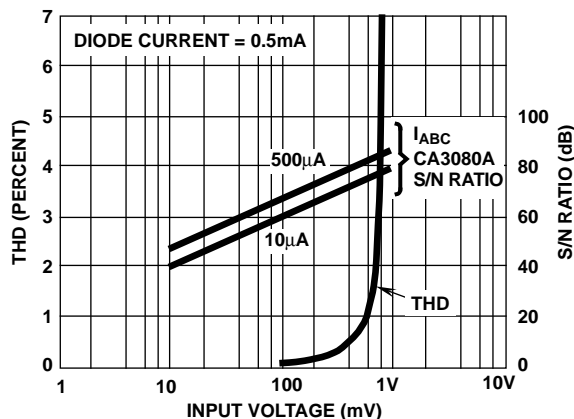
As long as the differential input signal to the OTA remains under 50mV peak-to-peak, the deviation from a linear transfer will remain under 5 percent. Of course, the total harmonic distortion will be considerably less than this value. Signal excursions beyond this point only result in an undesired "compressed" output. The reason for this compression can be seen in the transfer characteristic of the differential amplifier in Figure 3. Also shown in Figure 3 is a curve depicting the departure from a linear line of this transfer characteristic.

The actual performance of the circuit shown in Figure 4 is plotted in Figure 5. Both signal to noise ratio and total harmonic distortion are shown as a function of signal input. Figures 5B and 5C show how the signal handling capability of the circuit is extended through the connection of diodes on the input as shown in Figure 6<sup>[2]</sup>. Figure 7 shows total system gain as a function of amplifier bias current for several values of diode current. Figure 8 shows an oscilloscope reproduction of the CA3080 transfer characteristic as applied to the circuit of Figure 4. The oscilloscope reproduction of Figure 9

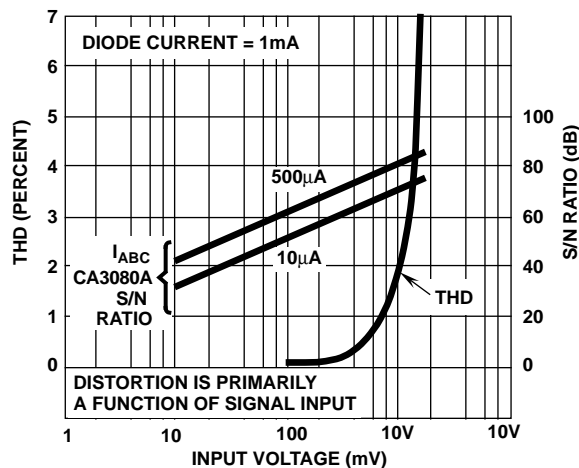
was obtained with the circuit shown in Figure 6. Note the improvement in linearity of the transfer characteristic. Reduced input impedance does result from this shunt connection. Similar techniques could be used on the OTA output, but then the output signal would be reduced and the correction circuitry further removed from the source of non linearity. It must be emphasized that the input circuitry is differential.



**FIGURE 5A.**

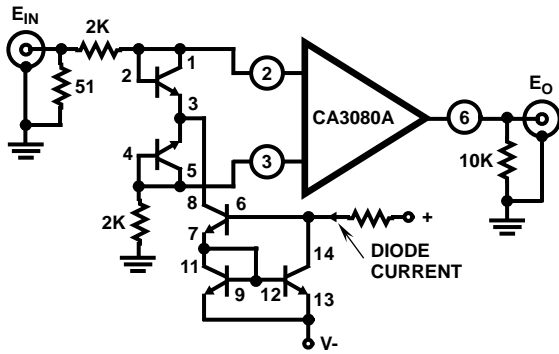


**FIGURE 5B.**



**FIGURE 5C.**

**FIGURE 5. PERFORMANCE CURVES FOR THE CIRCUIT OF FIGURES 4 AND 6**



Transistors from CA3046 array  
AGC System with extended input range

FIGURE 6. A CIRCUIT SHOWING HOW THE SIGNAL HANDLING CAPABILITY OF THE CIRCUIT OF FIGURE 4 CAN BE EXTENDED THROUGH THE CONNECTION OF DIODES ON THE INPUT

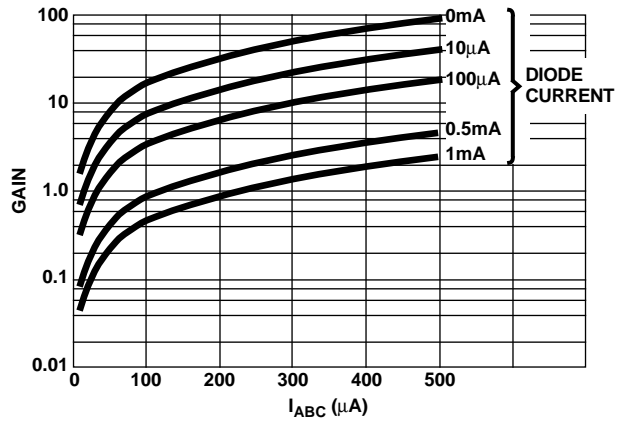
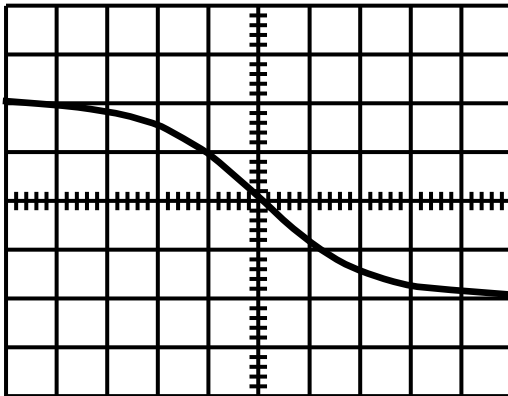
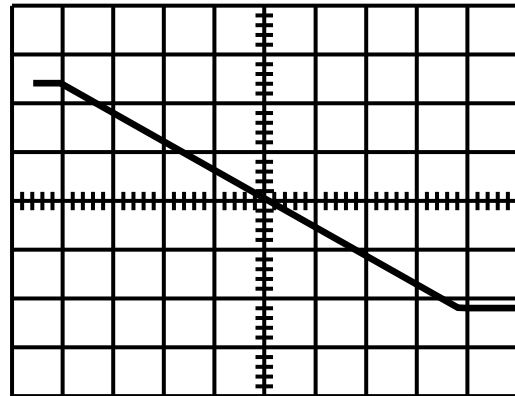


FIGURE 7. TOTAL SYSTEM GAIN AS A FUNCTION OF AMPLIFIER BIAS CURRENT FOR SEVERAL VALUES OF DIODE CURRENT



Horizontal: 25mV/Div. Vertical: 50 $\mu A$ /Div.  
 $I_{ABC} = 100\mu A$

FIGURE 8. OSCILLOSCOPE REPRODUCTION OF THE CA3080 TRANSFER CHARACTERISTIC AS APPLIED TO THE CIRCUIT OF FIGURE 4



Horizontal: 0.5V/Div. Vertical: 50 $\mu A$ /Div.  
 $I_{ABC} = 100\mu A$ , Diode Current = 1mA

FIGURE 9. OSCILLOSCOPE REPRODUCTION OF THE CA3080 TRANSFER CHARACTERISTIC AS APPLIED TO THE CIRCUIT OF FIGURE 6

### Simplified Differential Input to Single Ended Output Conversion

One of the more exacting configurations for operational amplifiers is the differential to single-ended conversion circuit. Figure 10 shows some of the basic circuits that are usually employed. The ratios of the resistors must be precisely matched to assure the desired common mode rejection. Figure 11 shows another system using the CA3080 to obtain this conversion without the use of precision resistors. Differential input signals must be kept under 126mV for better

than 5 percent nonlinearity. The common mode range is that of the CA3080 differential amplifier. In addition, the gain characteristic follows the standard differential amplifier  $g_m$  - temperature coefficient of  $-0.3\%/^{\circ}C$ . Although the system of Figure 11 does not provide the precise gain control obtained with the standard operational amplifier approach, it does provide a good simple compromise suitable for many differential transducer amplifier applications.

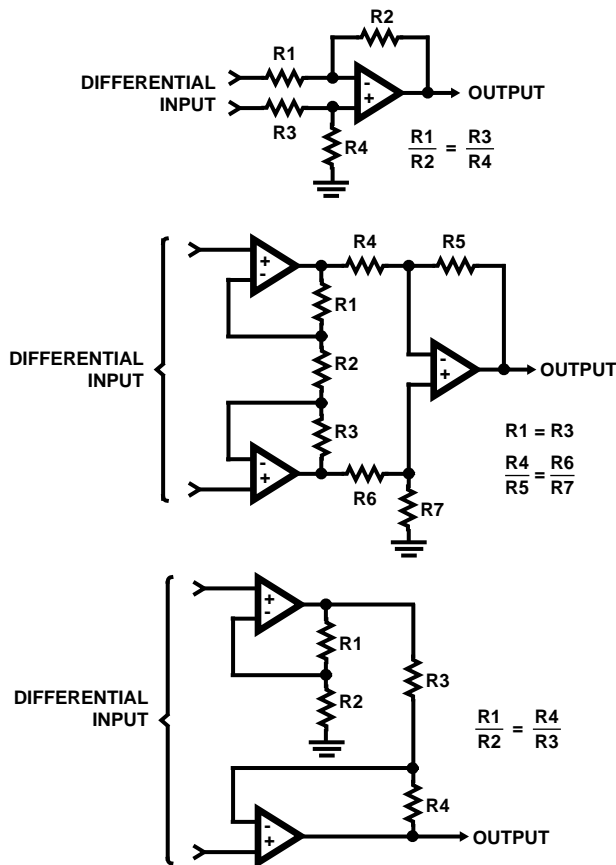
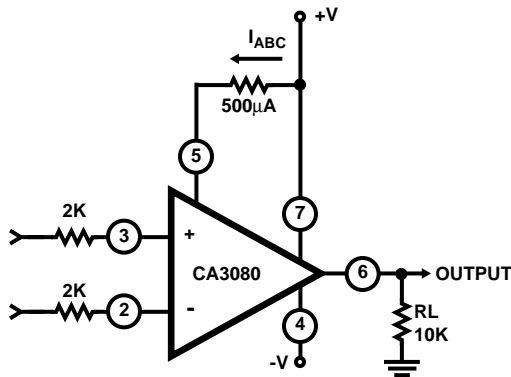


FIGURE 10. SOME TYPICAL DIFFERENTIAL TO SINGLE-ENDED CONVERSION CIRCUITS



NOTES:

1.  $A = g_m R_L$   
AT  $500\mu A, I_{ABC}$
2.  $g_m \approx 10mS$
3.  $\therefore A = 10mS \times 10K = 100$

FIGURE 11. A DIFFERENTIAL TO SINGLE ENDED CONVERSION CIRCUIT WITHOUT PRECISION RESISTORS

### The CA3094

The CA3094 offers a unique combination of characteristics that suit it ideally to use as a programmable gain block for audio power amplifiers. It is a transconductance amplifier in which gain and open-loop bandwidth can be controlled

between wide limits. The device has a large reserve of output-current capability, and breakdown and power dissipation ratings sufficiently high to allow it to drive a complementary pair of transistors. For example, a 12W power amplifier stage ( $8\Omega$  load) can be driven with peak currents of 35mA (assuming a minimum output transistor beta of 50) and supply voltages of  $\pm 18V$ . In this application, the CA3094A is operated substantially below its supply voltage rating of 44V max. and its dissipation rating of 1.6W max. Also in this application, a high value of open-loop gain suggests the possibility of precise adjustment of frequency response characteristics by adjustment of impedances in the feedback networks.

### Implicit Tone Controls

In addition to low distortion, the large amount of loop gain and flexibility of feedback arrangements available when using the CA3094 make it possible to incorporate the tone controls into the feedback network that surrounds the entire amplifier system. Consider the gain requirements of a phonograph magnetic cartridge system that uses a typical high quality magnetic cartridge.<sup>[3]</sup> A desirable system gain would result in from 2W to 5W of output at a recorded velocity of 1cm/s. Magnetic pickups have outputs typically ranging from 4mV to 10mV at 5cm/s. To get the desired output, the total system needs about 72dB of voltage gain at the reference frequency.

Figure 12 is a block diagram of a system that uses a passive or "losser" type of tone control circuit that is inserted ahead of the gain control. Figure 13 shows a system in which the tone controls are implicit in the feedback circuits of the power amplifier. Both systems assume the same noise input voltage at the equalizer and main-amplifier inputs. The feedback system shows a small improvement (3.8dB) in signal-to-noise ratio at maximum gain but a dramatic improvement (20dB) at the zero gain position. For purposes of comparison, the assumption is made that the tone controls are set "flat" in both cases.

### Cost Advantages

In addition to the savings resulting from reduced parts count and circuit size, the use of the CA3094 leads to further savings in the power supply system. Typical values of power supply rejection and common-mode rejection are 90dB and 100dB, respectively. An amplifier with 40dB of gain and 90dB of power supply rejection would require 316mV of power supply ripple to produce 1mV of hum at the output. Thus, no further filtering is required other than that given by the energy storage capacitor at the output of the rectifier system.

### Power Amplifier Using the CA3094

A complete power amplifier using the CA3094 and three additional transistors is shown schematically in Figure 14. The amplifier is shown in a single-channel configuration, but power supply values are designed to support a minimum of two channels. The output section comprises Q1 and Q2, complementary epitaxial units connected in the familiar "bootstrap" arrangement. Capacitor C3 provides added base drive for Q1 during positive excursions of the output. The circuit can be operated from a single power supply as well as from a split supply as shown in Figure 15. The changes required for 14.4V operation with a  $3.2\Omega$  speaker are also indicated in the diagram.

## Application Note 6077

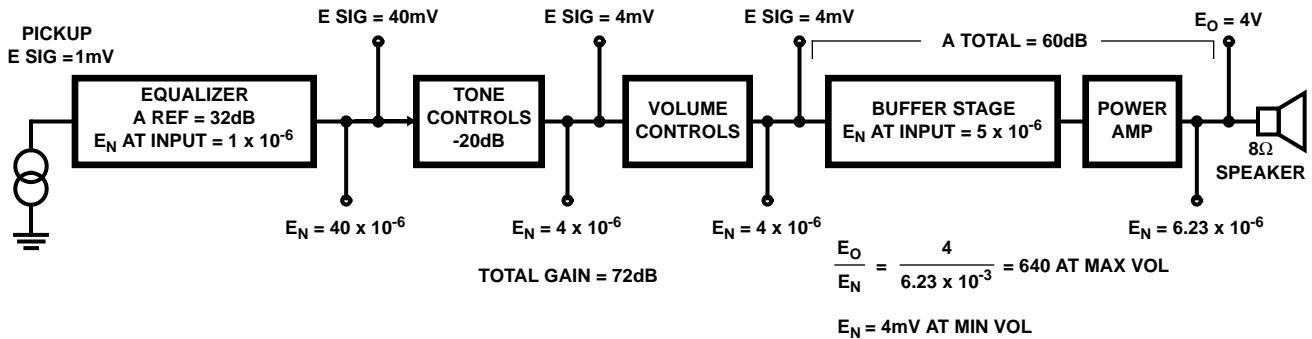


FIGURE 12. BLOCK DIAGRAM OF A SYSTEM USING A "LOSSER" TYPE TONE CONTROL CIRCUIT

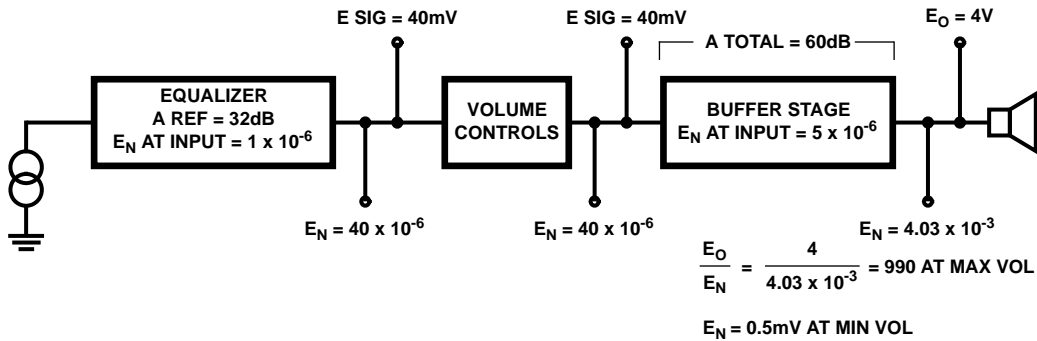


FIGURE 13. A SYSTEM IN WHICH TONE CONTROLS ARE IMPLICIT IN THE FEEDBACK CIRCUIT OF THE POWER AMPLIFIER

The amplifier may also be modified to accept input from ceramic phonograph cartridges. For standard inputs (equalizer preamplifiers, tuners, etc.) C1 is 0.047μF, R1 is 250kΩ, and R2 and C2 are omitted. For ceramic-cartridge inputs, C1 is 0.0047μF, R1 is 2.5MΩ, and the jumper across C2 is removed.

### Output Biasing

Instead of the usual two-diode arrangement for establishing idling currents in Q1 and Q2, a "V<sub>be</sub> Multiplier", transistor Q3, is used. This method of biasing establishes the voltage between the base of Q1 and the base of Q2 at a constant multiple of the base to emitter voltage of a single transistor while maintaining a low variational impedance between its collector and emitter (see Appendix A). If transistor Q3 is mounted in intimate thermal contact with the output units, the operating temperature of the heat sink forces the V<sub>be</sub> of Q3 up and down inversely with heat-sink temperature. The voltage bias between the bases of Q1 and Q2 varies inversely with heat sink temperature and tends to keep the idling current in Q1 and Q2 constant.

A bias arrangement that can be accomplished at lower cost than those already described replaces the V<sub>be</sub> multiplier with a 1N5391 diode in series with an 8.2Ω resistor. This arrangement does not provide the degree of bias stability of the V<sub>be</sub> multiplier, but is adequate for many applications.

### Tone-Controls

The tone controls, the essential elements of the feedback system, are located in two sets of parallel paths. The bass

network includes R3, R4, R5, C4, and C5. C6 blocks the dc from the feedback network so that the DC gain from input to the feedback takeoff point is unity. The residual DC output voltage at the speaker terminals is then

$$R1 \frac{R11 + R12}{R12}$$

where R1 is the source resistance. The input bias current is then

$$\frac{I_{ABC}}{2\beta} = \frac{(V_{CC} + V_{BE})}{2\beta R6}$$

The treble network consists of R7, R8, R9, R10, C7, C8, C9, and C10. Resistors R7 and R9 limit the maximum available cut and boost, respectively. The boost limit is useful in curtailing heating due to finite turn-off time in the output units. The limit is also desirable when there are tape recorders nearby. The cut limit aids the stability of the amplifier by cutting the loop gain at higher frequencies where phase shifts become significant.

In cases in which absolute stability under all load conditions is required, it may be necessary to insert a small inductor in the output lead to isolate the circuit from capacitive loads. A 3μH inductor (1A) in parallel with a 22Ω resistor is adequate. The derivation of circuit constants is shown in Appendix B. Curves of control action versus electrical rotation are also given.

# Application Note 6077

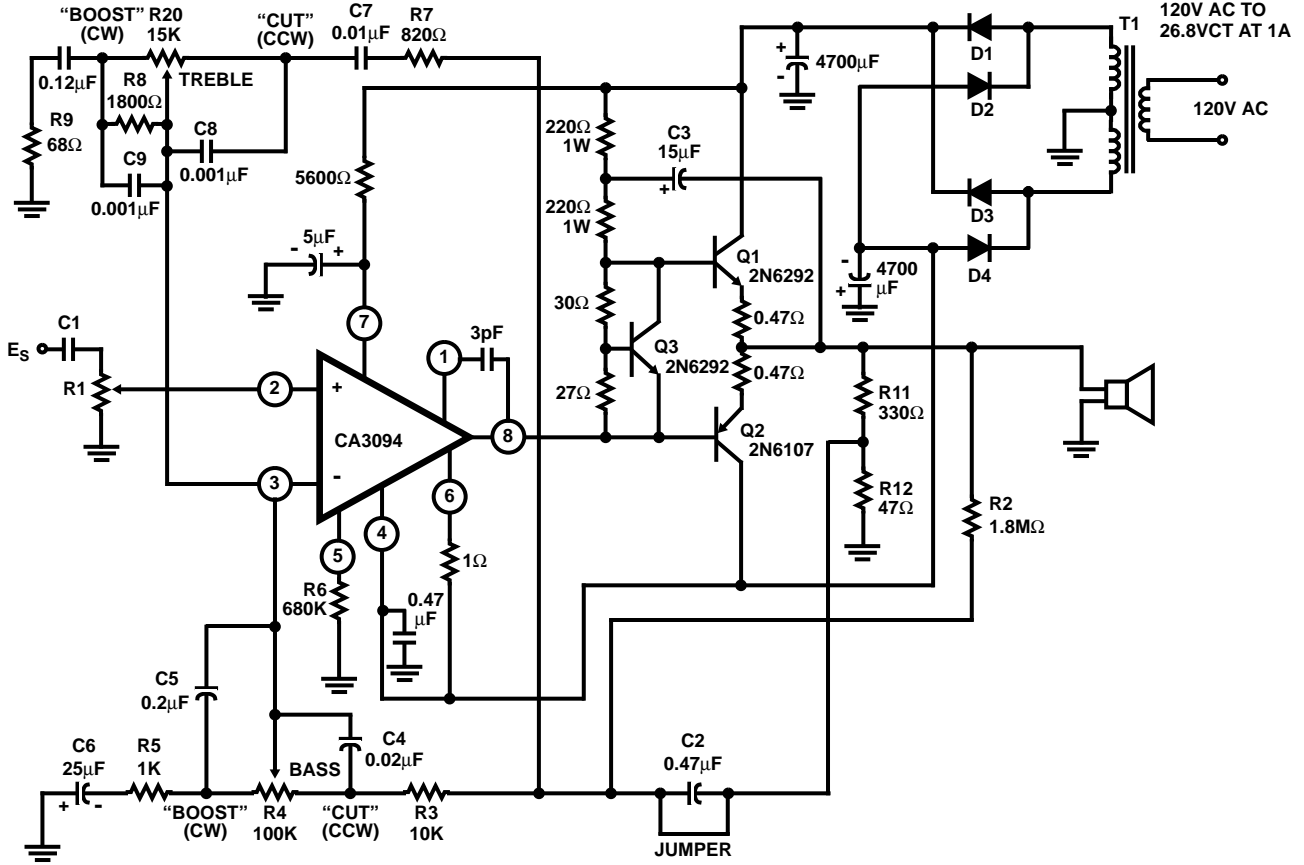


FIGURE 14. A COMPLETE POWER AMPLIFIER USING THE CA3094 AND THREE ADDITIONAL TRANSISTORS

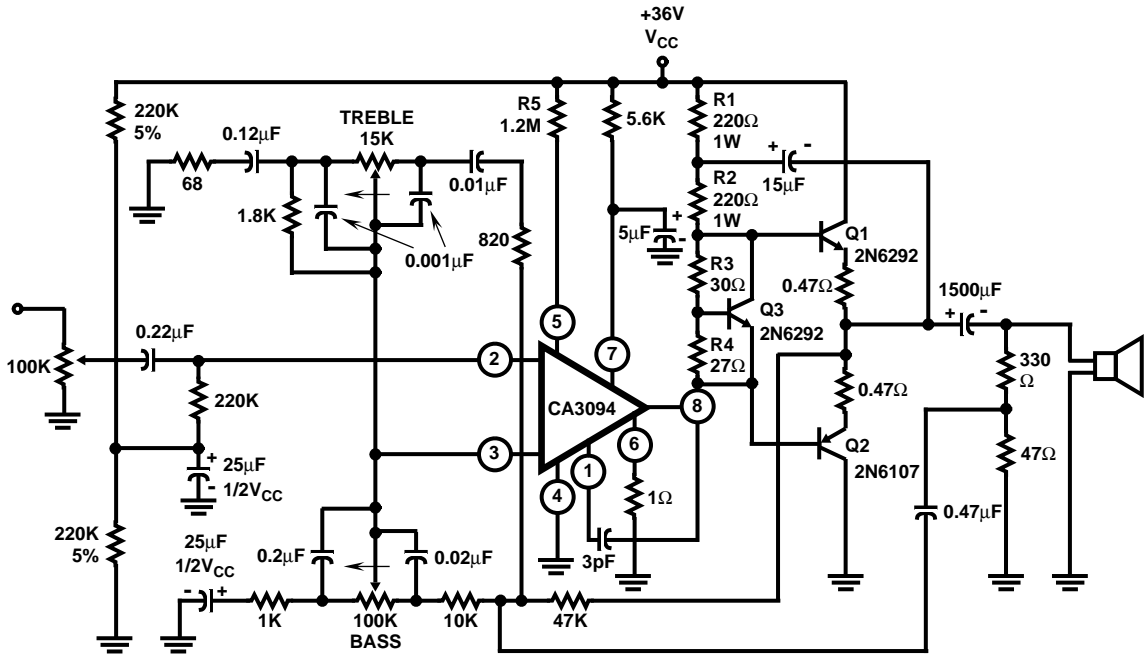


FIGURE 15. A POWER AMPLIFIER OPERATED FROM A SINGLE SUPPLY

**Performance**

Figure 16 is a plot of the measured response of the complete amplifier at the extremes of tone control rotation. A comparison of Figure 16 with the computed curves of Figure B4 (Appendix B) shows good agreement. The total harmonic distortion of the amplifier with an unregulated power supply is shown in Figure 17; IM distortion is plotted in Figure 18. Hum and noise are typically 700 $\mu$ V at the output, or 83dB down.

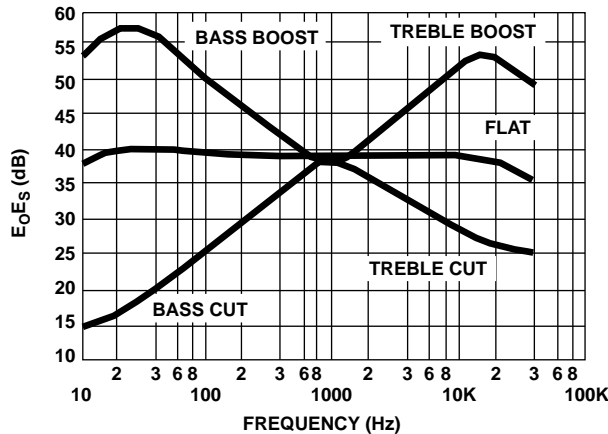


FIGURE 16. THE MEASURED RESPONSE OF THE AMPLIFIER AT EXTREMES OF TONE CONTROL ROTATION

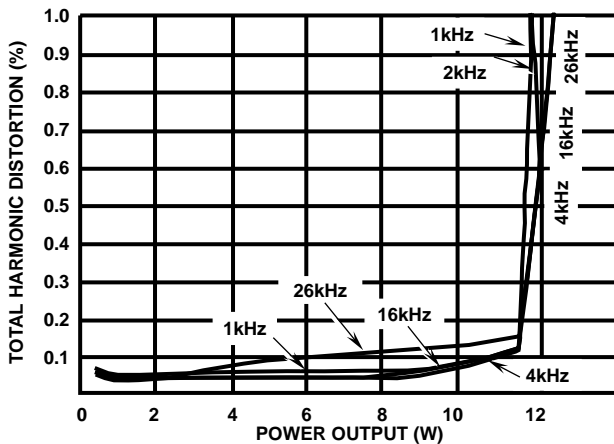


FIGURE 17. TOTAL HARMONIC DISTORTION OF THE AMPLIFIER WITH AN UNREGULATED POWER SUPPLY

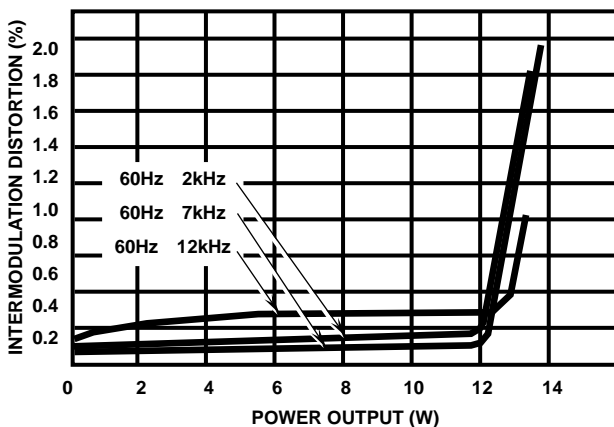


FIGURE 18. IM DISTORTION OF THE AMPLIFIER WITH AN UNREGULATED SUPPLY

**Companion RIAA Preamp**

Many available preamplifiers are capable of providing the drive for the power amplifier of Figure 14. Yet the unique characteristics of the amplifier, its power supply, input impedance, and gain make possible the design of an RIAA preamplifier that can exploit these qualities. Since the input impedance of the amplifier is essentially equal to the value of the volume control resistance (250k $\Omega$ ), the preamplifier need not have high output current capability. Because the gain of the power amplifier is high (40dB) the preamplifier gain only has to be approximately 30dB at the reference frequency (1kHz) to provide optimum system gain.

Figure 19 shows the schematic diagram of a CA3080 preamplifier. The CA3080, a low cost OTA, provides sufficient open-loop gain for all the bass boost necessary in AIAA compensation. For example, a  $g_m$  of 10mS with a load resistance of 250k $\Omega$  provides an open-loop gain of 68dB, thus allowing at least 18dB of loop gain at the lowest frequency. The CA3080 can be operated from the same power supply as the main amplifier with only minimal decoupling because of the high power supply rejection inherent in the device circuitry. In addition, the high voltage swing capability at the output enables the CA3080 preamplifier to handle badly over modulated (over-cut) recordings without overloading. The accuracy of equalization is within  $\pm 1$ dB of the RIAA curve, and distortion is virtually immeasurable by classical methods. Overload occurs at an output of 7.5V, which allows for undistorted inputs of up to 186mV (260mV peak).

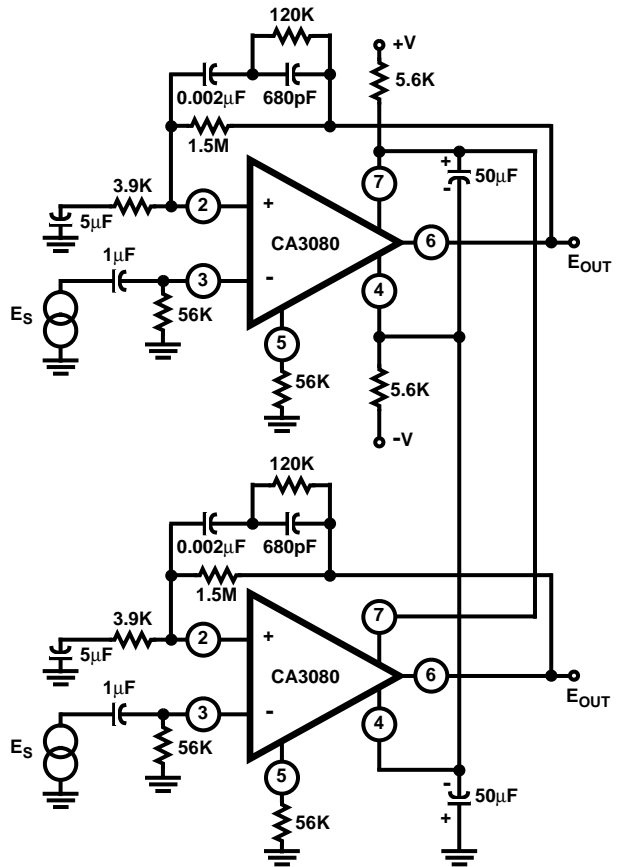


FIGURE 19. A CA3080 PREAMPLIFIER

## Appendix A - $V_{be}$ Multiplier

The equivalent circuit for the  $V_{be}$  multiplier is shown in Figure A1. The voltage  $E_1$  is given by:

$$E_1 = \frac{R_1 I}{\beta + 1} + V_{be} \left[ 1 + \frac{R_1}{R_2(\beta + 1)} \right] \quad (A1)$$

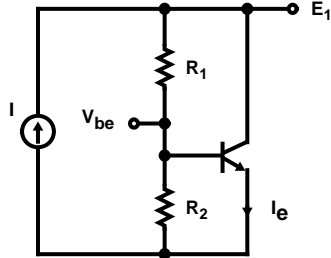


FIGURE A1. EQUIVALENT CIRCUIT FOR THE  $V_{be}$  MULTIPLIER

The value of  $V_{be}$  is itself dependent on the emitter current of the transistor, which is, in turn, dependent on the input current  $I$  since:

$$I_e = I - \frac{V_{be}}{R_2} \quad (A2)$$

The derivative of Equation A1 with respect to  $I$  yields the incremental impedance of the  $V_{be}$  multiplier:

$$\frac{dE_1}{dI} = Z = \frac{R_1}{\beta + 1} + \left[ 1 + \frac{BR_1}{(\beta + 1)R_2} \right] \left[ \frac{K_3 R_2}{R_2 I_e + K_3} \right] \quad (A3)$$

where  $K_3$  is a constant of the transistor  $Q_1$  and can be found from:

$$V_{be} = K_3 \ln I_e - K_2 \quad (A4)$$

Equation A4 is but another form of the diode equation:

$$I_e = I_S e^{\left[ \frac{qV_{be}}{KT} - 1 \right]} \quad (A5)$$

Using the values shown in Figure 14 plus data on the 2N6292 (a typical transistor that could be used in the circuit), the dynamic impedance of the circuit at a total current of 40mA is found to be 4.6Ω. In the actual design of the  $V_{be}$  multiplier, the value of  $IR_2$  must be greater than  $V_{be}$  or the transistor will never become forward biased.

## Appendix B - Tone Controls

Figure B1 shows four operational amplifier circuit configurations and the gain expressions for each. The asymptotic low frequency gain is obtained by letting  $S$  approach zero in each case:

$$\text{Bass Boost: } A_{LOW} = \frac{R_1 + R_2 + R_3}{R_2}$$

$$\text{Bass Cut: } A_{LOW} = \frac{R_1 + R_2 + R_3}{R_2 + R_3}$$

$$\text{Treble Boost: } A_{LOW} = \frac{C_1 + C_4}{C_4}$$

$$\text{Treble Cut: } A_{LOW} = \frac{C_1 + C_4}{C_4}$$

The asymptotic high-frequency gain is obtained by letting  $S$  increase without limit in each expression:

$$\text{Bass Boost: } A_{HIGH} = \frac{R_1 + R_2}{R_2}$$

$$\text{Bass Cut: } A_{HIGH} = \frac{R_1 + R_2}{R_2}$$

$$\text{Treble Boost: } A_{HIGH} = 1 + C_1 \left( \frac{C_3 + C_4}{C_3 C_4} \right)$$

$$\text{Treble Cut: } A_{HIGH} = \frac{C_2 + \frac{C_1 C_4}{C_1 + C_2}}{C_1 + C_2}$$

Note that the expressions for high frequency gain are identical for both bass circuits, while the expressions for low frequency gain are identical for the treble circuits.

Figure B2 shows cut and boost bass and treble controls that have the characteristics of the circuits of Figure B1. The value  $R_{EFF}$  in the treble controls of Figure B1 is derived from the parallel combination of  $R_1$  and  $R_2$  of Figure B2 when the control is rotated to its maximum counterclockwise position. When the control is rotated to its maximum clockwise position, the value is equal to  $R_1$ .

To compute the circuit constants, it is necessary to decide in advance the amounts of boost and cut desired. The gain expressions of Figure B1 indicate that the slope of the amplitude versus frequency curve in each case will be 6dB per octave (20dB per decade). If the ratios of boosted and cut gain are set at 10, i.e.:

$$\text{Bass Circuit: } A_{LOW(Boost)} = 10A_{MID}$$

$$A_{LOW(Cut)} = \frac{A_{MID}}{10}$$

$$\text{Treble Circuit: } A_{HIGH(Boost)} = 10A_{MID}$$

$$A_{HIGH(Cut)} = \frac{A_{MID}}{10}$$

then the following relationships result:

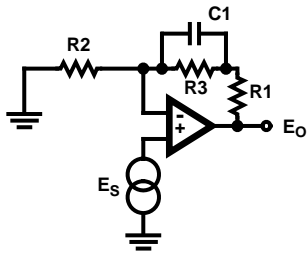
$$\text{Bass Circuit: } R_1 = 10R_2$$

$$R_3 = 99R_2$$

$$\text{Treble Circuit: } C_1 = 10C_4$$

$$C_2 = \frac{10C_4}{99}$$

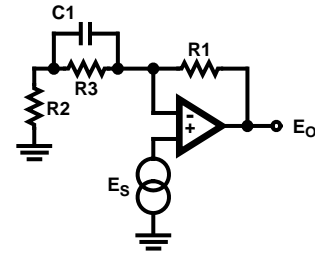




$$A = \left( \frac{R1 + R2 + R3}{R2} \right) \left[ \frac{1 + SC_1 \frac{(R2R3 + R1R3)}{(R1 + R2 + R3)}}{1 + SR3C1} \right]$$

$$A_{\text{LOW FREQUENCY}} = \frac{R1 + R2 + R3}{R2}$$

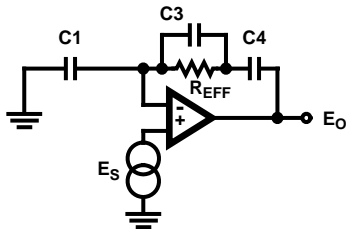
FIGURE B1 (A). BASS BOOST



$$A = \left( \frac{R1 + R2 + R3}{R2 + R3} \right) \left[ \frac{1 + SC_2 \frac{(R2R3 + R1R3)}{(R1 + R2 + R3)}}{1 + SC2 \left( \frac{R2R3}{R2 + R3} \right)} \right]$$

$$A_{\text{LOW FREQUENCY}} = \frac{R1 + R2 + R3}{R2 + R3}$$

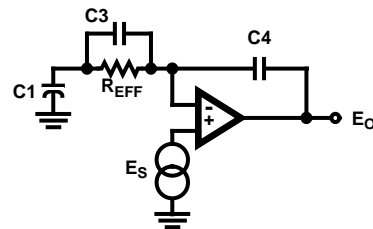
FIGURE B1 (B). BASS CUT



$$A = \left( \frac{C1 + C4}{C4} \right) \left[ \frac{1 + SR_{EFF} \frac{(C1 C4 + C3 C4 + C1 C3)}{(C1 + C4)}}{1 + SR_{EFF} C3} \right]$$

$$A_{\text{LOW FREQUENCY}} = \frac{C1 + C4}{C4}$$

FIGURE B1 (C). TREBLE BOOST



$$A = \left( \frac{C1 + C4}{C4} \right) \left[ \frac{1 + SR_{EFF} \frac{(C1 C4 + C2 C4 + C1 C2)}{(C1 + C4)}}{1 + SR_{EFF} (C1 + C2)} \right]$$

$$A_{\text{LOW FREQUENCY}} = \frac{C1 + C4}{C4}$$

FIGURE B1 (D). TREBLE CUT

FIGURE B1. FOUR OPERATIONAL AMPLIFIER CIRCUIT CONFIGURATIONS AND THE GAIN EXPRESSIONS FOR EACH

The unaffected portion of the gain (A high for the bass control and A low for the treble control) is 11 in each case.

To make the controls work symmetrically, the low and high frequency break points must be equal for both boost and cut.

Thus:

$$\text{Bass Control: } \frac{C1 R3 (R1 + R2)}{R1 + R2 + R3} = \frac{C2 R2 R3}{R2 + R3}$$

$$\text{and } C1 R3 = \frac{C2 R3 (R1 + R2)}{R1 + R2 + R3}$$

since  $R3 \cong R2 + R3$ ,  $C2 = 10C1$

$$\begin{aligned} \text{Treble Control: } R1 \frac{(C1 C4 + C3 C4 + C1 C3)}{C1 + C4} \\ = \frac{R1 R2}{R1 + R2} (C1 + C2) \end{aligned}$$

$$\text{and } R2C3 = \left( \frac{R1 R2}{R1 + R2} \right) \frac{(C1 C4 + C2 C4 + C1 C2)}{(C1 + C4)}$$

since  $C1 \cong 100C2, C2 = C3$  and  $C1 = 10C4, R1 = 9R2$

To make the controls work in the circuit of Figure 14, breaks were set at 1000Hz:

$$\text{for the base control } 0.1C1R1 = \frac{1}{2\pi \times 1000}$$

$$\text{and for the treble control } R1C3 = \frac{1}{2\pi \times 1000}$$

#### Response and Control Rotation

In a practical design, it is desirable to make "flat" response correspond to the 50% rotation position of the control, and to have an aural sensation of smooth variation of response on either side of the mechanical center. It is easy to show that the "flat" position of the bass control occurs when the wiper is advanced to 91% of its total resistance. The amplitude response of the treble control is, however, never completely "flat"; a computer was used to generate response curves as controls were varied.

Figure B3 is a plot of the response with bass and treble tone controls combined at various settings of both controls. The values shown are the practical ones used in the actual design. Figure B4 shows the information of Figure B3 replotted.

# Application Note 6077

ted as a function of electrical rotation. The ideal taper for each control would be the complement of the 100Hz plot for the bass control and the 10kHz response for the treble control. The mechanical center should occur at the crossover point in each case.

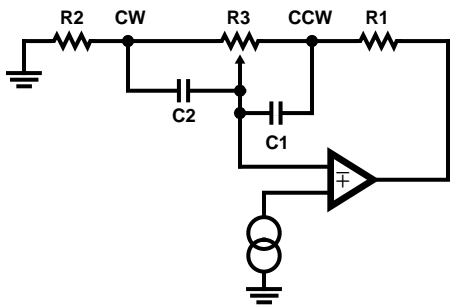


FIGURE B2 (A). BASS CONTROL

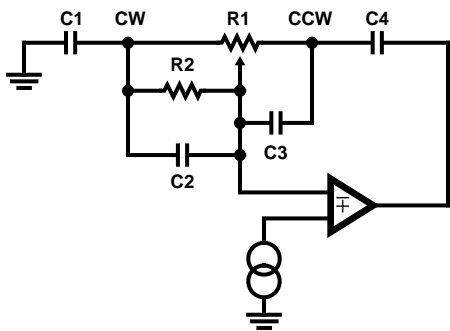


FIGURE B2 (B). TREBLE CONTROL

FIGURE B2. CUT AND BOOST BASS AND TREBLE CONTROLS THAT HAVE THE CHARACTERISTICS OF THE CIRCUITS IN FIGURE B1

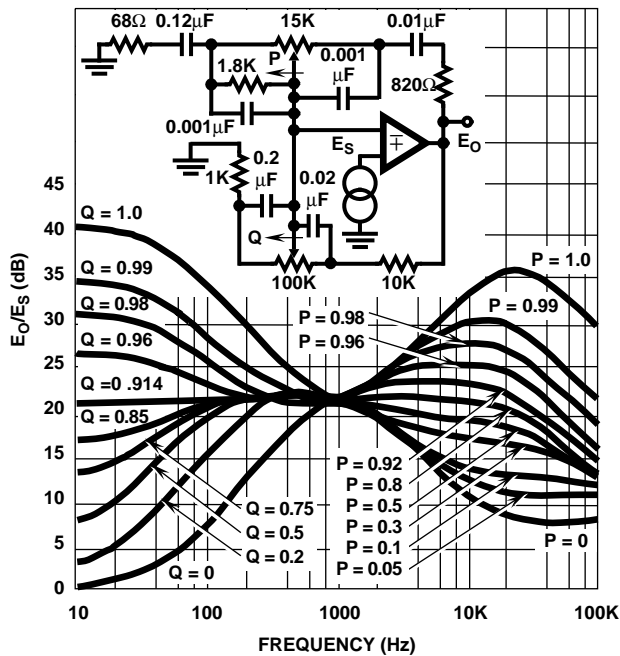


FIGURE B3. A PLOT OF THE RESPONSE OF THE CIRCUIT OF FIGURE 14 WITH BASS AND TREBLE TONE CONTROLS COMBINED AT VARIOUS SETTINGS OF BOTH CONTROLS

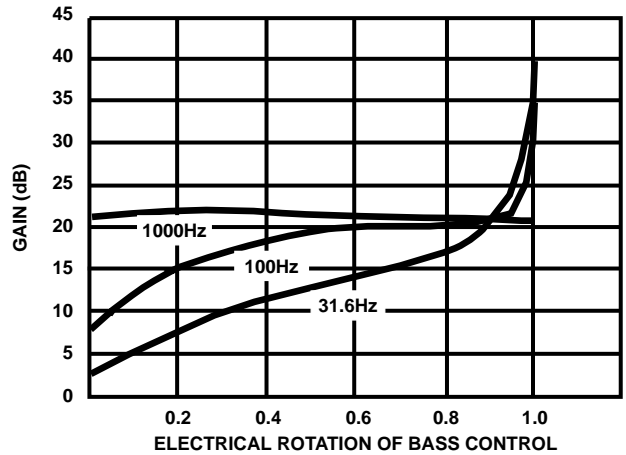


FIGURE B4 (A).

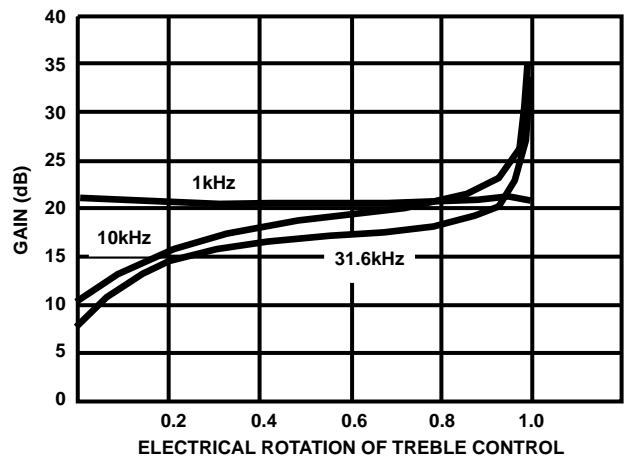


FIGURE B4 (B).

FIGURE B4. THE INFORMATION OF FIGURE B3 PLOTTED AS A FUNCTION OF ELECTRICAL ROTATION

## References

- [1] AN6668, "Applications of the CA3080 and CA3080A High Performance Operational Transconductance Amplifiers," H. A. Wittlinger, Harris Semiconductor.
- [2] "A New Wide-Band Amplifier Technique," B. Gilbert, IEEE Journal of Solid State Circuits, Vol. SC-3, No. 4, December, 1968.
- [3] "Trackability," James A. Kogar, Audio, December, 1966.